



MAGELAN

Leakage Sensor

Assembly instructions

Brief description:

blossom-ic radio and app controlled Leakage Sensor. For monitoring wet rooms, basements or even under washing machines and dishwashers. For early detection of unintentional water leakage to prevent major water damage. Can be used in combination with the Magelan Main Water Protector and the Magelan Siren. Can be used anywhere thanks to its 10-year battery. In combination with Gateway GT-100.

Contents...

Connection of the Gateway GT-100	3
Registration of the Leakage Sensor	3
Connection diagram.....	4
Control via blossomic app.....	5
Technical data.....	6
Safety instructions	6
Declaration of conformity.....	6
Warning notice	6
Intended Use.....	6

Connection of the Gateway GT-100

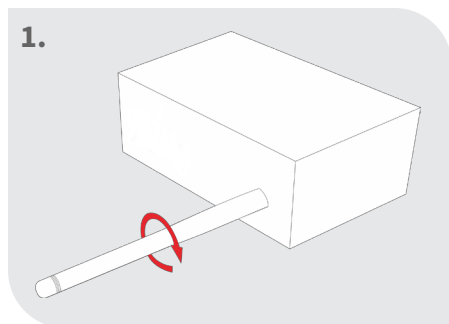

1. Screw on the antenna

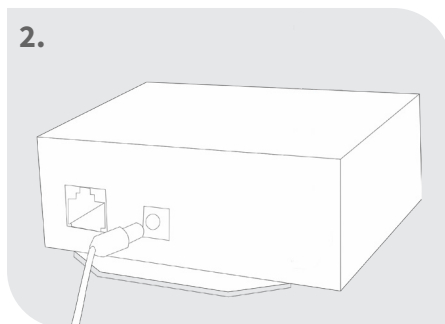

2. Connect power supply unit

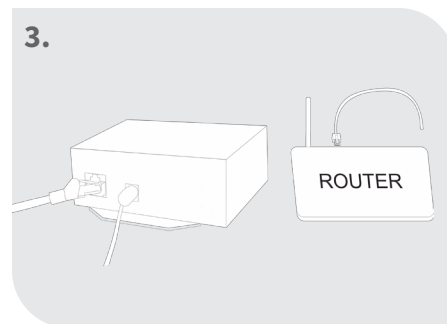

3. Connect the network cable

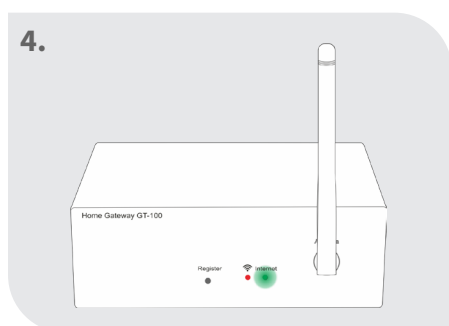

4. Check status

Green diode lights up constantly: Internet connection is establishing.

Green diode lights up constantly: Internet connection is successfully established

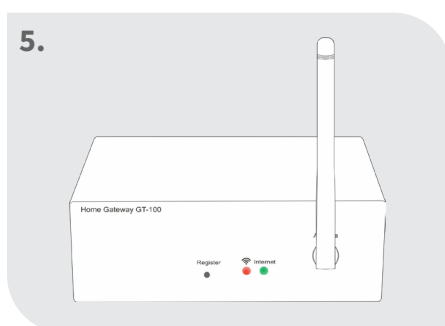

5. Both diodes light up permanently: Gateway active

Hint:

Functionality in the home safe area. Internet connection is used for convenient setting and control via smartphone.

The system functionality is guaranteed even if no Internet connection is available.

Registration of the Leakage Sensor

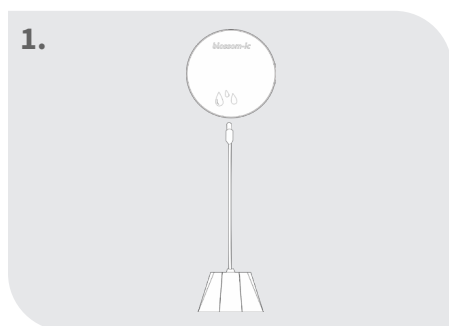

1. Connect floor Sensor to control element

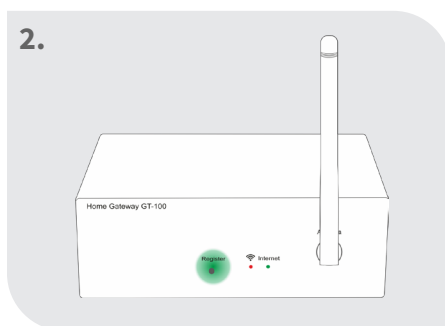

2. Press the „Register“ button on the gateway

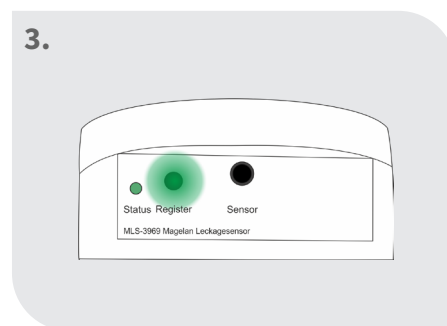

3. Press the „Register“ button on the control element for 3 sec.

4.

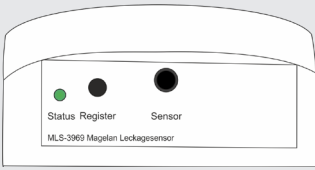

LED on control element starts flashing, Leakage Sensor registers

5.

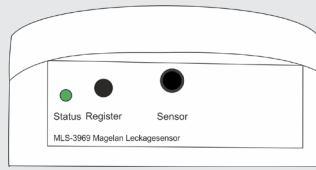

LED on the control element lights up continuously
=> The registration was successful

Note:

If the LED on the control unit goes out after blinking => The registration has failed

Connection diagram

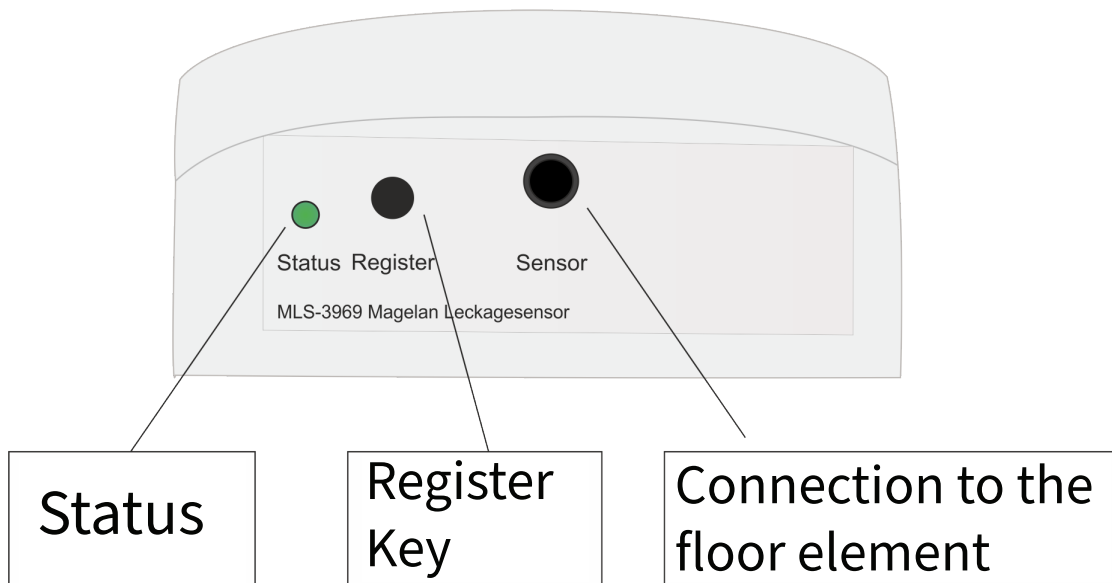

Control via blossomic app



Leakage system

When a Leakage Sensor is registered, this icon appears in the system overview

Extensions for the Leakage system

1. Siren (acoustic signal)
2. Main Water Protector (monitoring of the main water pipe and immediate closing in case of leakage)

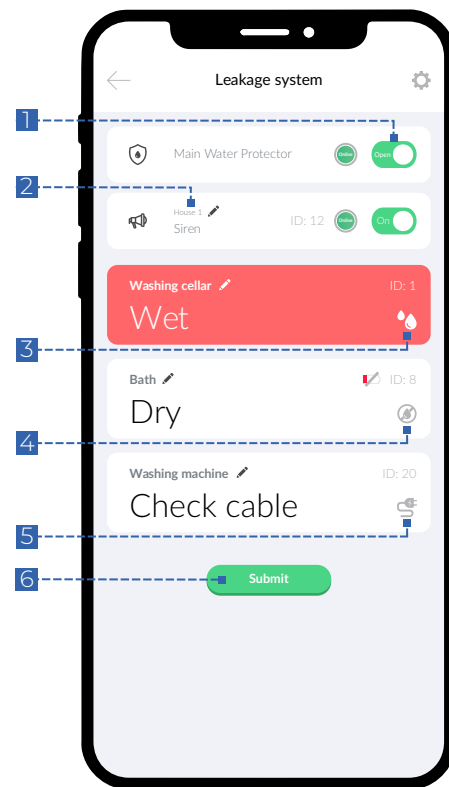

1 Activate / deactivate

2 Naming the Siren

3 Leakage detected

4 Bath is active and no leakage was detected

5 Error message

Check cable: A cable may be defective or not correctly plugged into the device

6 Save changes

All changes must always be confirmed

Note:

If the Main Water Protector is closed in the app, it can be opened again via app. However, if the Main Water Protector is closed by a leak, the Main Water Protector must be reactivated manually on the app. (An opening of the protector via app is not possible after a leakage)

Technical data

Technical data - Magelan Leakage Sensor

• Ambient temperature	0 ~ 50°C
• Ambient humidity	90% (non-condensing)
• Power	10-year-battery Lithium 3.6V
• Dimension Control element	Ø 75 mm x H31 (mm)
• Dimension Floor sensor	L38 x W58 x H38 (mm)
• Wireless frequency	2.4GHz, ISM Band, 16 channels
• Protection class	IP 30
• RF-Test	RED 2014/53/EU
• CE	Available
• RoHS	Available
• Type of antenna	PCB antenna

Safety instructions

Attention! Important Note:

Installation and assembly of electrical devices may only be carried out by a qualified electrician. Failure to observe the assembly and installation instructions can result in fire or other dangers.

Declaration of conformity

Hereby blossom-ic GmbH & Co. KG hereby declares that the following product: Magelan Leakage Sensor MLS-3969 is in compliance with the essential requirements and other relevant provisions of Directive 2014/53/EU. The complete declaration of conformity can be found at the following address: [www.blossomic.de/downloads Declaration of conformity](http://www.blossomic.de/downloads/Declaration%20of%20conformity).

Warning notice

The Leakage Sensor is not suitable for children and must not be used as a toy. Store and dispose of packaging materials in a child-resistant manner. Do not disassemble the Leakage Sensor, as it does not contain any user-serviceable parts. If defects occur, please return the Leakage Sensor to the dealer. This appliance may be used by children over 8 years of age and by persons with reduced physical, Sensory or mental abilities or lack of experience and knowledge, if they have been supervised or instructed in the safe use of the appliance and understand the dangers involved. Children must not play with the device. Cleaning and user maintenance must not be performed by children without supervision.

Intended Use

The Magelan Leakage Sensor is only suitable for monitoring potential danger points of water leakage.



blossom-ic

 intelligent controls

blossom-ic GmbH & Co. KG

Oberer Buxheimer Weg 60, 87700 Memmingen, Germany

P: +49 8331-756 965 80 **E:** info@blossomic.de

W: www.blossomic.de